

1. TO CREATE "+" LINES: FOLD IN HALF HORIZONTALLY AND PERPENDICULARLY, THEN UNFOLD. TO CREATE "X" LINES: FOLD IN HALF DIAGONALLY FROM THE CORNERS BOTH WAYS, THEN UNFOLD. THEN, FOLD EACH CORNER INTO THE CENTER POINT AND UNFOLD.

2. FLIP IT OVER

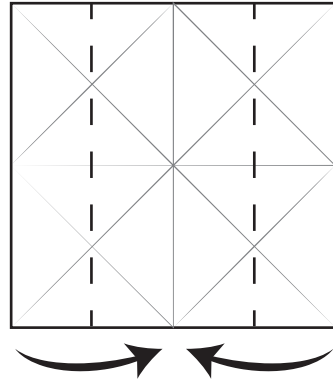

2. FOLD THE EDGES INTO THE CENTER, LIKE CLOSING A CUPBOARD, THEN UNFOLD.

3. TURN IT 90°

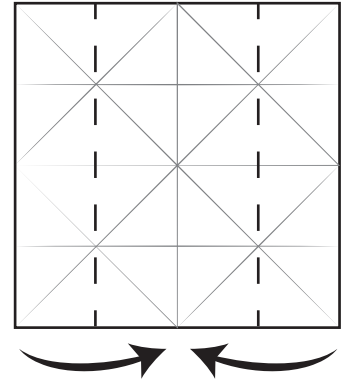

3. FOLD THE SIDES INTO THE MIDDLE, LIKE CLOSING A CUPBOARD.

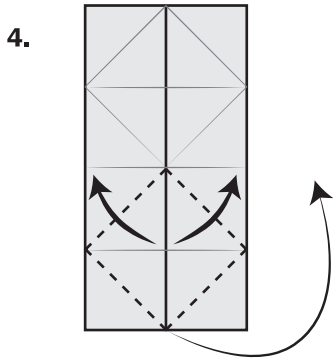

4. FOLD OUT THE BOTTOM CORNERS ALONG THE DOTTED LINES, WHILE BRINGING THE BOTTOM EDGE UP TO CENTER.

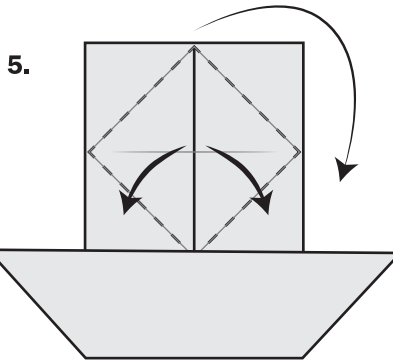

5. REPEAT STEP 4 ON THE TOP, FOLDING OUT THE TOP CORNERS ALONG THE DOTTED LINES, AND BRINGING THE TOP EDGE DOWN TO THE CENTER.

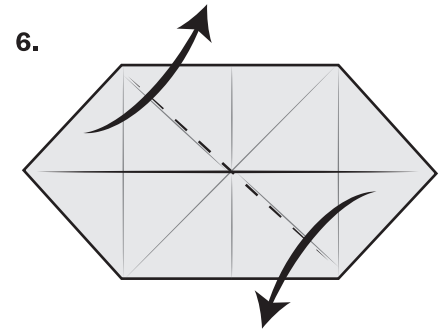

6. FOLD OUT TWO POINTS ALONG THE DOTTED LINES.

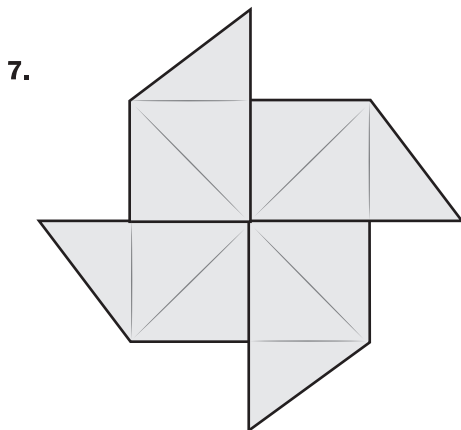

7.

POST A PICTURE ONLINE WITH HASHTAG: #PCAA2020

DON'T FORGET TO TAG US!

 /preventchildabuseamerica

 @pcaamerica

 @pcaamerica